

**CONCRETE SUMPS  
AND  
IMMERSED SURFACES  
SOLUTIONS FOR REPAIR AND COATING**



## Table of contents

CONCRETE SUMPS .....	1
AND.....	1
IMMERSED SURFACES .....	1
Concrete Sump and Basin Repair Manual .....	3
Preparation .....	3
Chemicals and Concrete .....	4
Chlorine and Calcium .....	4
Sulfuric Acid and Concrete.....	4
Chlorides (Salts).....	5
Other Damage .....	5
Freeze Thaw .....	5
Basin Settlement .....	6
Repair of the Basin.....	8
Structural Issues .....	8
Surface Preparation.....	8
Reinforcement Fabric.....	9
ARCHITECTURAL DRAWINGS .....	10
APPENDIX A.....	12
ULTRA-FLEX ECO 5000 PHYSICAL PROPERTIES CHART .....	12
APPENDIX B .....	13
CHEMICAL RESISTANCE CHART .....	13
APPENDIX C .....	14
WATERPROOFING CONCRETE SLABS AND CONTAINMENT FOR COOLING TOWERS (General Specification) .....	14

# Concrete Sump and Basin Repair Manual

## Preparation

There are a large number of concrete sumps, basins and surfaces that have been in service for long periods of time without having been coated to prevent deterioration. In the past, it was a common misconception that concrete was impermeable and impervious to chemical attack. Portland cement has very little tolerance for acids and caustic chemicals. We know differently now and must be able to spot problems before we approach a job so that we can intelligently address each problem and provide solutions for our customers. ULTRA-FLEX ECO 5000 and the ECO friendly ULTRA-FLEX 5000 FR (Class A Fire rated) membranes were developed to address these problems. Lava-Liner, Ltd., the inventor and original manufacturer of EvapLiner and EvapLiner FRA improved upon these successful product formulations and has not only made the resulting ULTRA-FLEX ECO 5000 AND ULTRA-FLEX 5000FR environmentally friendly but also on the part of the 5000FR antibacterial.

Before you can apply ULTRA-FLEX ECO 5000 or ECO friendly ULTRA-FLEX 5000FR liquid membranes, you must ascertain what problems exist in the substrate and how to repair them before attempting to apply ULTRA-FLEX. The structural integrity of the concrete must be in good shape or you must rehabilitate it to a point that the use of a coating will be effective and the chances of a coating failure or breach are negated. The ULTRA-FLEX Membrane System is an unparalleled coating system for waterproofing, containment and basins for cooling towers and power stations. The terms ULTRA-FLEX ECO 5000 and ULTRA-FLEX 5000FR are interchangeable for purposes of application in this manual.

Preparation is the all important key to a successful application of an ULTRA-FLEX Membrane System. Not only must the substrate be clean and dry but it must also be in good shape. The following illustrations will point out a number of problems you will possibly encounter in fixing and coating a concrete basin and provide you with several ways to correct the problems before coating.

We do not intend to try to provide a solution for the systemic causes of the corrosion and deterioration problems, but only to:

1. Spot the problems that cause the corrosion and inform the customer.
2. Spot any engineering or repair issues that must be addressed before coating.
3. Repair any structural problems and concrete slab deterioration.
4. Understand how and why ULTRA-FLEX ECO 5000 can aid in the prevention of further corrosion and deterioration.
5. Provide a long term solution to your customers.

It is important that the customer understand that the ongoing treatment of water in any cooling tower or immersed substrate requires a constant monitoring to make sure the water does not

contain any chemicals that will continue to destroy the concrete or the ULTRA-FLEX coated basin. A good relationship with their water treatment company is also important.

In most instances where you are going to coat a concrete basin, you will want to have a repair kit that will provide you the materials to address almost all problems you will encounter. We will outline later a basic list of some materials that will allow you to avoid having to leave and return to the site to address problems once you are there to repair and coat the concrete basin.

## **Chemicals and Concrete**

Many chemicals will cause premature deterioration of concrete. In the cooling tower industry, the most common problems will be related to chlorine, chlorides (salts), sulfuric other acids used to treat the water to prevent bacterial growth or to adjust the pH of the water and reduce corrosion.

ULTRA-FLEX ECO 5000 and 5000FR have a very high resistance to aqueous acids and base chemicals in high concentrations. With few exceptions, ULTRA-FLEX is impervious to the chemicals used in water treatment. The physical properties of the cured ULTRA-FLEX ECO 5000 and 5000FR can be found in Appendix A. A list of some of the chemicals and the concentrations that will not affect ULTRA-FLEX ECO 5000 or 5000FR is attached as Appendix B.

To help you understand and explain in simple terms what occurs when chemicals attack concrete for potential customers, we will give a brief example of what happens in the some of the above instances without getting into the chemistry detail.

### **Chlorine and Calcium**

Concrete contains calcium in the form of lime. Chlorine, over time, will penetrate concrete and bind with the calcium to form calcium chloride, a salt that is very soluble in water. Once in chlorine ions are in solution with the water, they will leach the calcium from the concrete rendering it porous and eventually destroy the structural integrity of the concrete.

### **Sulfuric Acid and Concrete**

Sulfuric acid reacts with the calcium in concrete and will form a new compound commonly known as gypsum. Another product that is formed called ettringite will lift corroded concrete away from sound concrete and cause a faster deterioration by exposing new surface to acid attack. Both of these will leave a rough and porous surfaced concrete with substantially reduced integrity. Another way to tell if sulfuric may be at issue is that the concrete will have a pale yellow color.



An illustration of deterioration and discoloration due to long term exposure to dilute sulfuric acid in the water treatment system.

### **Chlorides (Salts)**

Because of the continuous monitoring of the water quality in a tower the formation of chlorides is a given. Simple evaporation can cause concentration of elements and the addition of chemicals will cause the formation of salts in the water. Chlorides are the enemy of structural steel used to reinforce concrete. When the concrete is penetrated by water, it will carry chloride ions with it. This will in turn attack the rebar in concrete and cause corrosion. When this occurs, oxidized metal will begin to expand and will eventually cause spalling. Spalling occurs by the separation of concrete from the metal rebar through internal forces caused by oxidation of the metal within the concrete and results in sections of concrete being split from the surface.

### **Other Damage**

#### **Freeze Thaw**

In areas subject to harsh winter conditions, the concrete, after having absorbed water over time, may in the presence of chlorides or other chemicals begin to deteriorate and spall. Water, when frozen, increases in size. When it is encapsulated in concrete, it will slowly begin to increase in size and cause small fissures and cracks, these will in turn become filled with water and again every time it freezes, the cracks will become larger until at some point the concrete will begin to break apart.



The foregoing picture is an example of extreme spalling.

### **Basin Settlement**

Most concrete basins are poured on grade concrete slabs and not generally poured with walls and parapets as an integral part of the structure. The walls are poured separately and leave a joint at the base that will allow water to penetrate between the slab and wall base. The foregoing illustration of extreme spalling also shows where the wall was poured separately from the floor slab and you can see the moisture along the base of the wall that has not dried. This illustration also shows how the basin has settled over time due to an erosion of the base under the slab. The slab was not coated and eventually cracked and allowed water to penetrate through the slab to the earth below and washed out the material over time. The following picture also illustrates the effects of concrete failure and cracking due to erosion of the base under the slab.



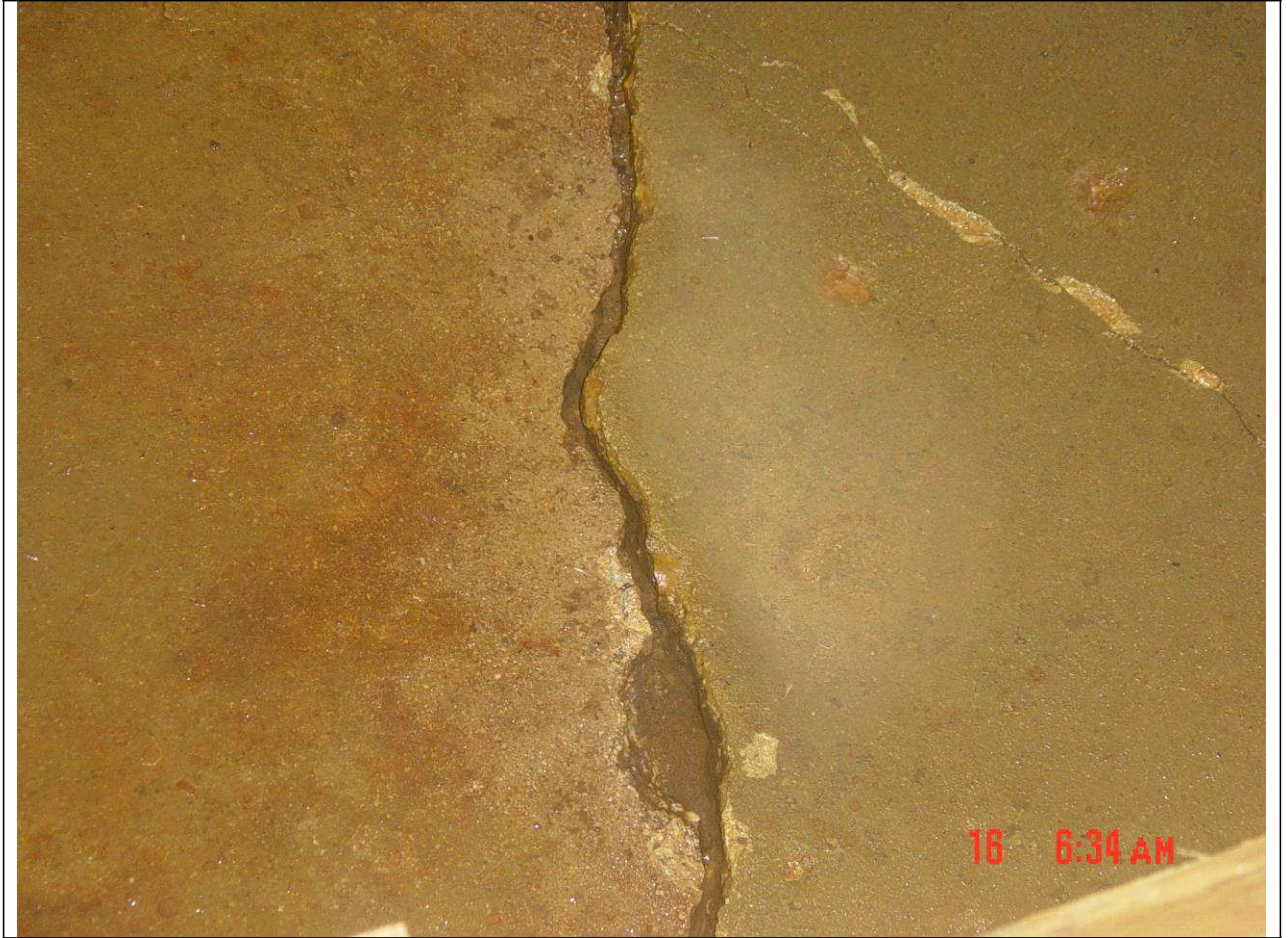

Cracking and separation due to base erosion under slab.

The following shows how the water was leaking from the slab and beginning to erode the base next to the basin which could result in substantial damage to the adjacent structure. Note the water accumulation between the tower basin and the brick building and the moisture wicking up the brick wall.



The pictures show the accumulation of water from a leaky basin.

## Repair of the Basin

### Structural Issues

Before the basin is coated, all structural issues such as cracks and spalling should be fixed. Your basic repair kit should include hydraulic cement that cures rapidly (usually within 3-4 hours) and forms a crystalline bond with the old concrete. Hydraulic cements that have been successfully used to repair cooling tower basins include the following:

Manufacturer	Product Name
Xypex	Patch 'n Plug
Quikrete	Water Stop Cement
Unitex	Hydraulic Cement
Five Star Products	EZ Cure Repair Mortar / Structural Concrete

The following illustration shows a spall and joint crack that have been repaired using hydraulic cement prior to coating with ULTRA-FLEX ECO 5000.

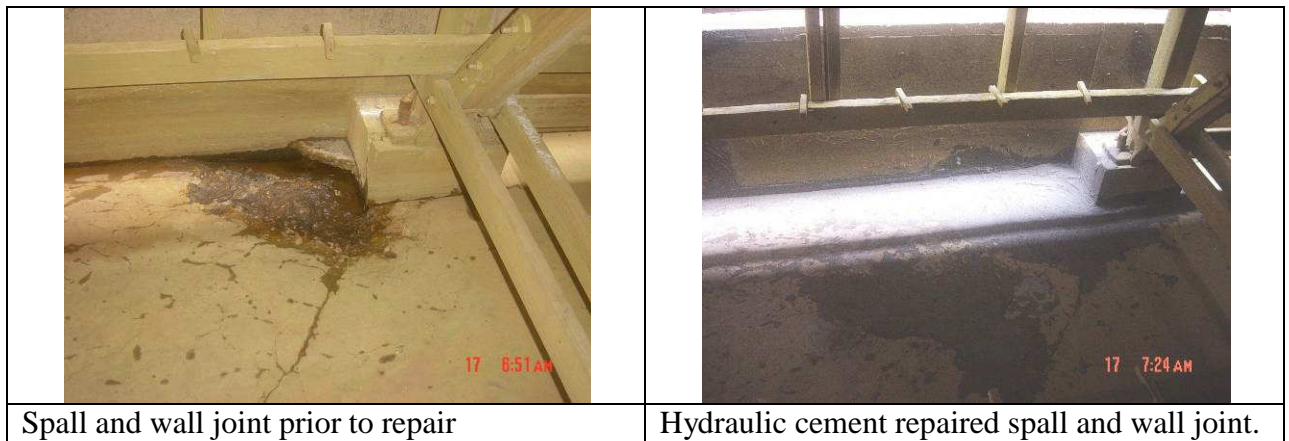

### Surface Preparation

Once the major spalls, cracks and joints have been repaired, the surface of the basin should be pressure washed or sand blasted to remove any biofilm and accumulated dirt or chemical residue on the surface. Rinse, blow off or vacuum all dust or dirt from the basin after it has dried. The basin should be dry enough so that the concrete surface does not contain more than 5% moisture. Please read the application specification for methods for determining the moisture in concrete if you are unsure of how dry the concrete has become.



In order to rehabilitate the concrete surface and to seal off moisture that has accumulated in the concrete from reacting with the ULTRA-FLEX ECO 5000 application, it is important to apply a sealer coat of ULTRA-FLEX EP-990C, concrete penetrating epoxy. EP-990C was specifically designed to penetrate concrete and to seal off moisture as well as to provide increased ULTRA-FLEX ECO 5000 adhesion to the concrete basin. EP-990C is a two component epoxy that is blended on site at the ratio of two parts A to one Part B. EP-990 C has a pot life of approximately 1-2 hours at 25°C/77°F.

EP-990C is applied at a rate of approximately 200 square feet per gallon. It is very thin and will rapidly soak into concrete. EP-990C is easily applied using a simple garden sprayer or by roller. An example of application using a garden sprayer is pictured below. The use of airless spray equipment is NOT recommended due to the fine mist it will create and potential for inhalation by personnel. Additionally, airless equipment will not provide a sufficient amount of material in a single pass due to its fine atomization. All concrete treated with EP-990C must not have more than 5% moisture content.

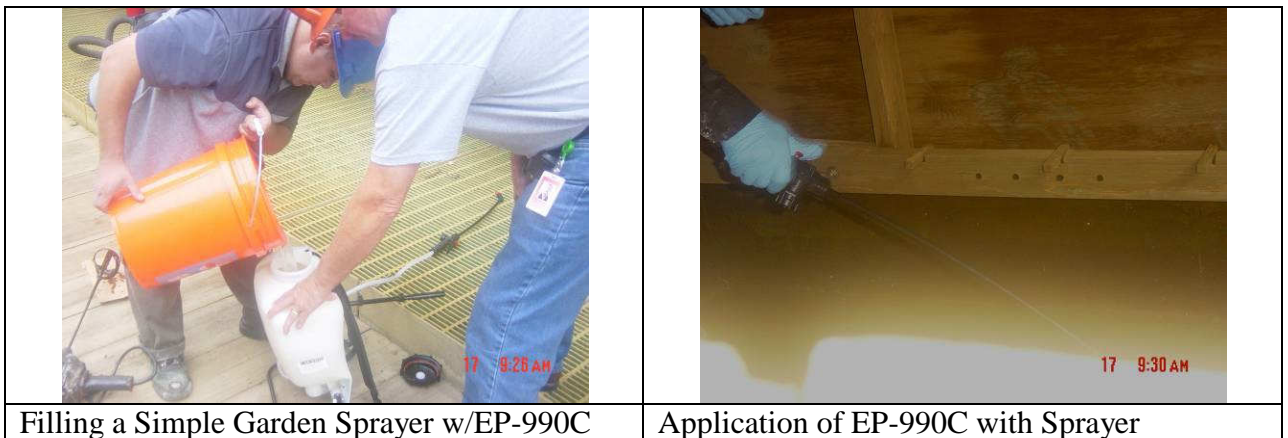

### Reinforcement Fabric

All joints and cracks over 1/8 of an inch and all areas that have been patched using hydraulic cement should be reinforced with a polyester or polypropylene fabric. The manner of coating cracks is illustrated below.

## ARCHITECTURAL DRAWINGS

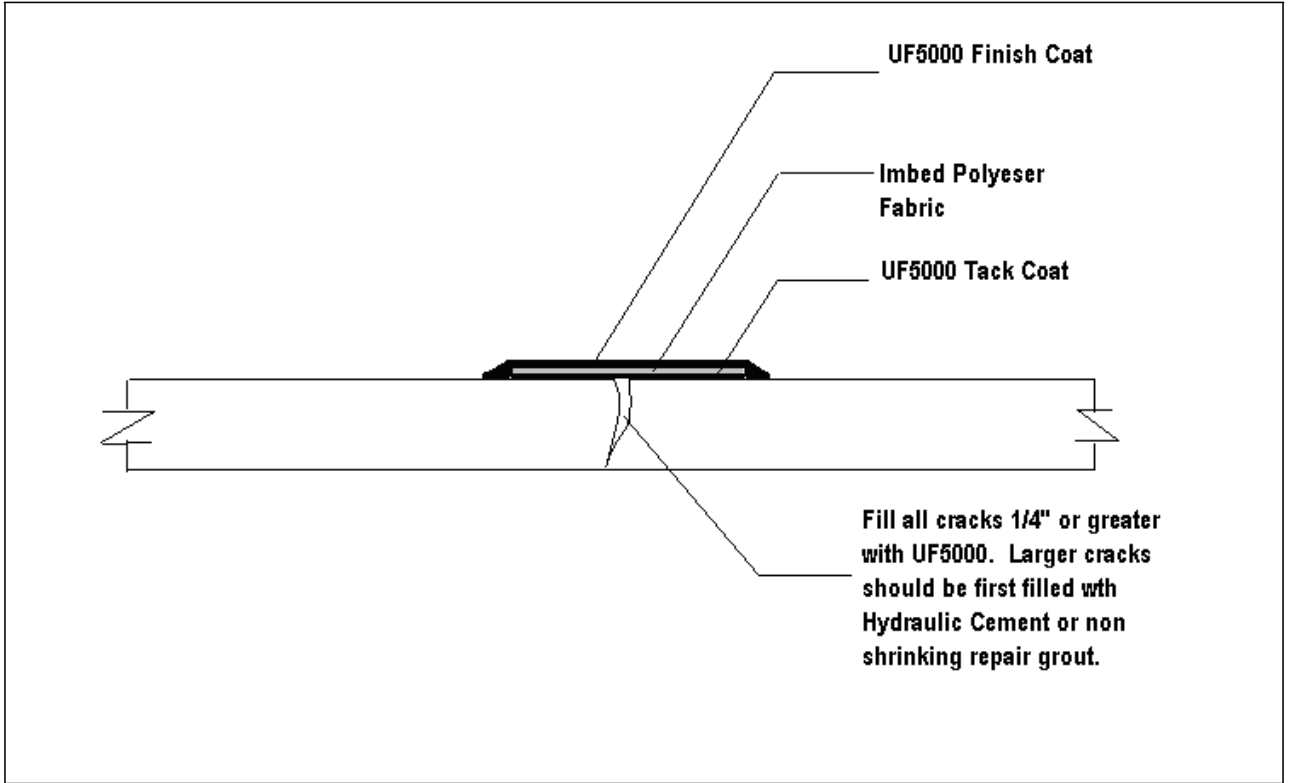

When addressing transitions from floor to wall, the procedure for preparing the joints and coating with ULTRA-FLEX ECO 5000 using a reinforcing fabric is shown below.

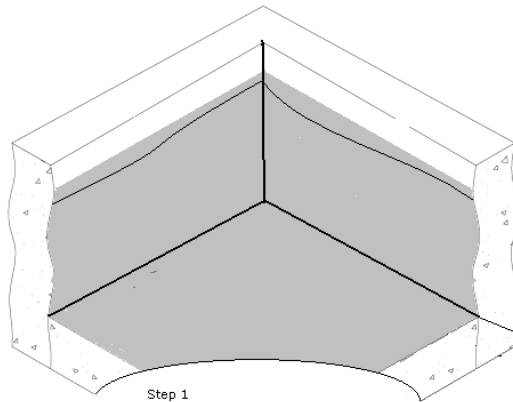

Step 1  
Applied Ultra-Flex 990-C to  
approximately 4" above high water  
line.

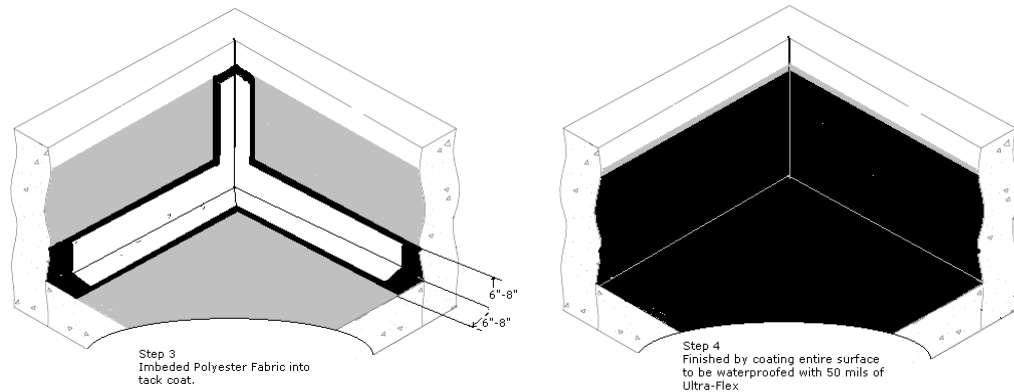

All concrete applications are not alike but the foregoing will help understand what difficulties might be encountered and how to address them in order to complete a professional job. The following general specification and guideline attached as Exhibit C can be used as a basis for presenting a specification for application of ULTRA-FLEX ECO 5000 to a potential customer.

## APPENDIX A

### ULTRA-FLEX ECO 5000 PHYSICAL PROPERTIES CHART

<u>PHYSICAL PROPERTIES</u>	<u>TEST METHOD</u>	<u>RESULTS</u> ECO 5000
Tensile (PSI)	ASTM D412	> 3250
Elongation (%)	ASTM D412	> 130
Tensile, Modulus	ASTM D882	> 3200
Graves Tear (Die C, pl 20" min.)	ASTM D624	> 250
Shore D Hardness (Inst-5sec)	ASTM D2240	40-50
Moisture Vapor Transmission (Perm-in)	ASTM E96	>.02
Percent Solids	Calculated	96%(±2%)
VOC g/l	ASTM D3960	2.04
Abrasion Resistance (Wt. Loss)	ASTM D4060	> 0.01



## APPENDIX B



### CHEMICAL RESISTANCE CHART

The adjacent will provide general exposure guidelines as to the resistance of ULTRA-FLEX ECO 5000 and 5000FR against certain chemicals and combinations. Although this information is believed to be reliable, LAVA-LINER has no particular application, installation, or exposure experience of ULTRA-FLEX membranes and suitable tests should be carried out by the end user.

Where concentrations of chemicals are listed, the rating applies to all concentrations up to and including the concentration indicated. Maximum temperature for continuous service in some specific atmospheres is 150<sup>0</sup>F (71<sup>0</sup>C). For most applications, however, maximum service temperature is much higher. Consult LAVA-LINER representative for actual use recommendations.

#### FOOTNOTE

R – Recommended / suitable continuous

CR - Conditionally recommended for splash/spill conditions

1 - Max service temp. limited to 100<sup>0</sup> F

2 - Max service temp. limited to 150<sup>0</sup> F.

NC - Incompatible

Acetic Acid, Glacial	CR
Acetic Acid, >15% <30%	R1
Acetic Acid, >5 % <10%	R
Ammonium Hydroxide,> 50%	NC
Ammonium Hydroxide, < 15%	R1
Biological Oxidation Ponds	R
Bromine, Saturated	R
Chromatic Acid 7%	CR
Sulfuric Acid 6%	CR
Chlorine, Saturated	R
Citric Acid, > 15%	R
Copper Sulfate (Sat.) Solution in Water	R
Crude Oil (Continuous Emersion)	NC
Deionized Water	R
Diesel Fuel	NR
Ethylene Glycol (Antifreeze)	R
Ferric Chloride, < 54%	R 2
Hydrochloric Acid (muriatic). < 15% Solution in Water	R
Hydrogen Sulfide, Vapor37% H2O, Fresh	CR
Hydrogen Sulfide, Vapor Over Saturated Solution	CR
Methanol	CR
Nitric Acid, 10%	R
Phosphoric Acid, 10%	R
Sewage Disposal Plant (Activated Sludge Sedimentation Tanks)	R
Salt	R
Sodium Dichromate 12%	R
Sodium Hydroxide 10%	R1
50% 72 hrs	R1
40% 48 hrs	R2
Sodium Hypochlorite, 5.25%	R
Soil Burial	R
Sodium Silicate, < 41 %	R
Sulfuric Acid, 5%-40%	R
Trisodium Phosphate< 10%	R
H <sub>2</sub> O	R

specifications are requested, contract is let or work is begun:

## APPENDIX C

### WATERPROOFING CONCRETE SLABS AND CONTAINMENT FOR COOLING TOWERS (General Specification)

#### 1) GENERAL

A) This is a guide specification for the application of ULTRA-FLEX ECO 5000 or ULTRA-FLEX 5000FR as a waterproofing and protective membrane over new or retrofitted concrete reservoirs and basins for cooling towers. The terms ECO 5000 and 5000FR are equally interchangeable for this specification.

#### 2) QUALITY ASSURANCE

- A) LAVA-LINER requires that this system must be installed by a certified representative and shall be in compliance with all specifications herein and approved by LAVA-LINER or its duly authorized representative.
- B) Requisite Paperwork and Submittals to LAVA-LINER or Representative.
- C) To ensure that the requisite minimum standards for warranties are met, compliance with the following must be completed and forwarded to LAVA-LINER for review and approval.
- i) Project specifications must be verified as complied with, signed and dated by the applicator.
  - ii) Work orders and change orders deviating from the specifications must be submitted and accompany the verified project specifications.
  - iii) LAVA-LINER and/or its authorized representative must submit request for Warranty Issuance to LAVA-LINER within 10 working days from the final inspection.
- D) The following projects must obtain prior approval by LAVA-LINER before

i) Projects where ULTRA-FLEX ECO 5000 is to come into contact with chemicals in excess of those concentrations as set forth in the Chemical Resistance Charts for ULTRA-FLEX ECO 5000, petroleum distillates or chemicals not listed in the Chemical Resistance Charts.

#### 3) DESCRIPTION

- A) ULTRA-FLEX ECO 5000 is a cold applied, two-component, liquid urethane. It cures to form a tough, durable, seamless, water impermeable barrier. ULTRA-FLEX ECO 5000 may be brushed, rolled, spray or squeegee applied and retains its flexibility in hot or cold environments.
- B) ULTRA-FLEX ECO 5000 can be applied as a membrane over newly cured or existing, concrete surfaces. See Paragraph 6) A) below for limitations on curing requirements.
- C) The system provides for a fabric reinforced membrane.

#### 4) MATERIALS

- i) ULTRA-FLEX ECO 5000 PART "A"
- ii) ULTRA-FLEX ECO 5000 PART "B"
- iii) ULTRA-FLEX ECO 5000 AP (Adhesion Promoter)
- iv) ULTRA-FLEX EP-990C Part A (Concrete Penetrating Epoxy) and ULTRA-FLEX EP-990C Part B (Concrete Penetrating Epoxy), 2:1 ratio for mixing.

#### 5) SAFETY

- A) Construction should be done with equipment and procedures designed to minimize danger to personnel and materials. It is recommended that good safety practices be followed when installing the ULTRA-FLEX ECO 5000 membrane system.
- B) All safety standards and recommendations for safety and handling hazardous materials issued by OSHA, EPA and other appropriate

federal and state governmental and regulatory agencies must be followed.

- C) All Material Safety Data Sheets must be complied with and maintained on site or readily available to the personnel working the site.
  - D) The LAVA-LINER CONCRETE APPLICATION MANUAL shall be maintained on site and readily available to personnel working with ULTRA-FLEX products.
- 6) CONCRETE CURING
- A) NEW CONCRETE: A curing period is necessary for all concrete surfaces to be coated with ULTRA-FLEX ECO 5000. Portland Cement Concrete shall appear dry at the time of application of ULTRA-FLEX ECO 5000. This curing period is needed for the concrete to attain proper hardness and for evaporation of excess water to prevent blistering, which could be caused by vapor pressure underneath the membrane film. Recommended curing of concrete varies from 28 days to six months depending upon surface conditions and coating used. Recommended procedure for new concrete is to moisture cure, using plastic film, wet burlap or water spray; pre-coat with a float finish to Class "B" tolerances and then surface with ULTRA-FLEX ECO 5000.
  - B) Refer to the LAVA-LINER MANUAL for methods to determine moisture and content.
- 7) PREPARATION OF SUBSTRATE
- A) ULTRA-FLEX ECO 5000 is applied on a clean, dry, and structurally sound concrete base.
  - B) Any oil and/or grease spots must be thoroughly cleaned. If paint or a previous coating has been applied, the surface must be lightly sanded. All paint or previous coatings that are loose or flaking must be removed.
  - C) The following is a list of normal practices used in surface preparation:
    - i) Inspect and clean the surface thoroughly.
    - ii) Repair structural defects (i.e., cut out blisters in prior coatings and secure any loose sections, fill in voids and honeycombs).
    - iii) Repair or replace flashings, counter flashings, gravel stops, vents, drains, etc.
    - iv) All weak spots should be reinforced and repaired, checking particularly for damage at the weakest points.
    - v) Mask and protect surrounding structures, which are not to be covered with ULTRA-FLEX ECO 5000.
  - D) If the concrete substrate is porous, a primer coat or an epoxy sealer may be required to prevent out gassing and the formation of bubbles. Formation of bubbles that can form as a result of entrapped air or moisture can be addressed through the use of EP-990C (Concrete Penetrating Epoxy) 4 hours prior to coating with ULTRA-FLEX ECO 5000.
- 8) INCOMPATIBLE SUBSTRATES
- A) Coal Tar products or solvent borne caulks or pastes are **not** compatible with ULTRA-FLEX ECO 5000.
- 9) DETAILS AND SPECIAL CONSTRUCTION
- A) All details and special construction such as vents, edges, flashings, counter flashings, parapets, curbed systems, equipment and sign supports, protrusions, drains and similar functions shall be consistent with the construction details set forth in the ULTRA-FLEX ECO 5000 CONCRETE APPLICATION MANUAL.
  - B) The above sections shall be sealed in the following manner.
    - i) STEP-1 Apply a tack coat of ULTRA-FLEX ECO 5000 around a protrusion, flashing, drain, etc to an area approximately 4 inches on each of the horizontal and vertical surfaces.
    - ii) STEP-2 Evenly imbed a 6" wide piece of polyester fabric into the tack coat.

- iii) STEP-3 Coat the imbedded fabric and tack coated area with ULTRA-FLEX ECO 5000.

10) PHASE CONSTRUCTION

- A) No phase construction should take place if:
  - i) Material temperature is below 50°F at time of application.
  - ii) Surface temperature is below 40°F.
  - iii) Surface moisture is present or rain is imminent.
  - iv) Surface temperature drops below the dew point.
  - v) Other conditions are obviously unsuitable.
  - vi) Concrete is in a temperature rising/curing mode.

11) JOINTS

- A) Treatment of major expansion joints with ULTRA-FLEX ECO 5000 should be consistent with the ULTRA-FLEX ECO 5000 CONCRETE APPLICATION MANUAL and Architectural Drawings included therein.
- B) Hairline cracks (non-working) up to 1/8 inch may be bridged with ULTRA-FLEX ECO 5000. If cracks exceed 1/8 inch but are less than ¼ inch and do not impair the structural integrity of the substrate, they may be in the following manner:
  - i) STEP 1 - Apply a tack coat of ULTRA-FLEX ECO 5000 at the crack to 3 inches on each side of the crack.
  - ii) STEP 2 - Center and imbed 6 inch wide strip of polyester fabric over the crack into the wet ULTRA-FLEX ECO 5000.
  - iii) STEP 3 - Coat over polyester fabric with ULTRA-FLEX ECO 5000.
  - iv) STEP 4 - Recoat over tack coat and polyester fabric during final application of ULTRA-FLEX ECO 5000

12) PROPORTIONING AND MIXING ULTRA-FLEX ECO 5000

- A) MIXING FOR BRUSH, ROLLER, SQUEEGEE OR "HOT POT" SPRAYING - Mix ULTRA-FLEX ECO 5000 components with a "Mortar Mixer" or other similar

mixer approved by LAVA-LINER for a FULL THREE MINUTES. (ULTRA-FLEX ECO 5000 is packaged in pre-proportioned mixing containers and should not be mixed in proportions other than that specifically prepackaged by LAVA-LINER)

- B) Hand mixing of the two components shall not be used except for small quantities of less than one gallon. (Components shall be proportionately reduced from original packaging.)
- C) Plural component spray mixing shall be preset at a ratio or prepolymer (Part A) to activator (Part B) of 7:1 by weight or 9:1 by volume.
- D) See the ULTRA-FLEX ECO 5000 CONCRETE APPLICATION MANUAL for specific details for spraying either air-assisted or plural component spray equipment.

13) APPLICATION OF ULTRA-FLEX ECO 5000

- A) ULTRA-FLEX ECO 5000 may be applied by brush, roller, spray or squeegee on horizontal surfaces in one pass to a minimum thickness of 50 mils dry film thickness. When spray, brush or roller applied on vertical surfaces, two or more passes are required to achieve a 50-mil dry film thickness. Squeegee application is not recommended on vertical surfaces. Wet coverage rate is approximately 3.55 gallons per 100 square feet.

14) REINFORCED MEMBRANE SYSTEM

- A) Where it is desirable to reinforce the membrane system, ULTRA-FLEX ECO 5000 may be applied in two coats using an imbedded polyester fabric. This is especially advantageous when applying a membrane system to steep embankments or walls to insure a minimum thickness and coverage. The application of ULTRA-FLEX ECO 5000 in a reinforced system is accomplished in the following manner:
  - i) STEP 1 Apply a coat of ULTRA-FLEX ECO 5000 to an area approximately 2-4 inches greater than the width of the polyester fabric roll.



- ii) STEP 2 Center and imbed the polyester fabric into the wet ULTRA-FLEX ECO 5000.
- iii) STEP 3 Recoat over polyester fabric with ULTRA-FLEX ECO 5000.
- iv) STEP 4 Apply a second tack coat on the concrete surface adjacent to the prior application of reinforced ULTRA-FLEX ECO 5000.
- v) STEP 5 Center and imbed a new layer of polyester fabric into the new coat of ULTRA-FLEX ECO 5000 insuring that the new fabric layer overlaps the previously imbedded polyester fabric by 6 inches.
- vi) STEP 6 – Recoat over the new polyester fabric with ULTRA-FLEX ECO 5000.

15) RECOATING

- A) ULTRA-FLEX ECO 5000 must be recoated within four hours to obtain maximum interlayer adhesion. If the membrane has cured for more than four hours, it must be lightly abraded with a wire brush or

sandpaper and pretreated with ULTRA-FLEX AP (Adhesion Promoter).

16) JOINT OVERLAP

- A) Should rain or other conditions require work stoppage, prepare for joint lines.
- B) Joint lines shall be clean and straight. The overlap shall be six inches minimum to assure an impervious joint.
- C) When the membrane has cured for more than four hours, all areas to be coated shall be lightly abraded with a wire brush or sandpaper. The abraded surface shall be treated with ULTRA-FLEX AP (Adhesion Promoter) at least 30 minutes and no more than four hours before applying the new ULTRA-FLEX ECO 5000.